

# NICORE CONNECTION DETAIL

## DETAIL OF BEARING ON STEEL BEAM

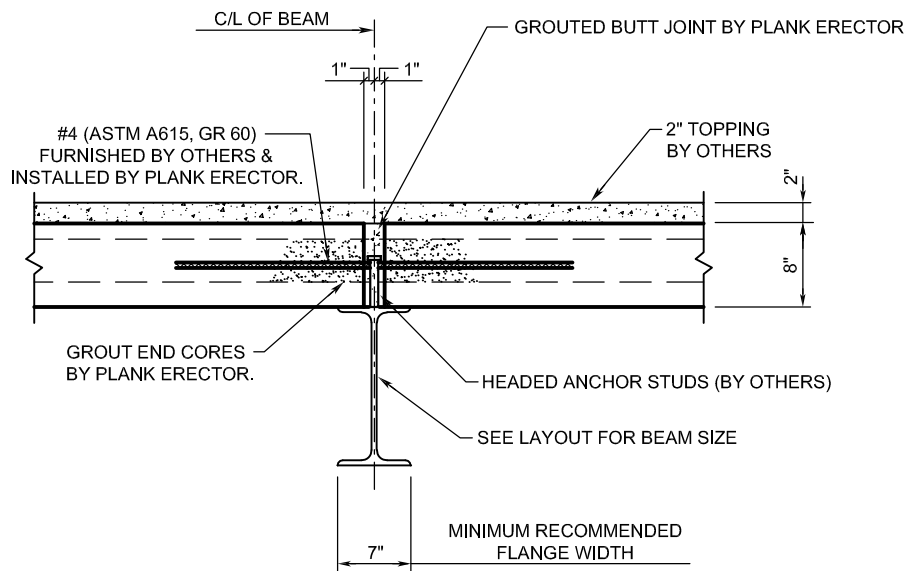

### NOTES:

1. NITTERHOUSE WILL PROVIDE A BROOMED FINISH IN ORDER TO CREATE A COMPOSITE TOPPING. C.I.P. TOPPING BY OTHERS IS TO BE 3,000 PSI. (NORMAL WEIGHT CONCRETE).
2. THE DESIGN OF CONNECTIONS FOR HOLLOW CORE PLANK TO OTHER BUILDING COMPONENTS IS THE RESPONSIBILITY OF THE ENGINEER OF RECORD, SINCE THEY ARE PART OF THE GLOBAL DESIGN OF THE STRUCTURE.
3. NITTERHOUSE WILL PROVIDE A SMOOTH FINISH FOR INSTALLATION OF ROOFING MATERIALS BY OTHERS.
4. WELD PLATES ARE FOR BRACING THE COMPRESSION FLANGE OF THE STEEL BEAM AND FOR TRANSFERRING DIAPHRAGM FORCES. THEY ARE NOT TO HOLD THE PLANKS ON THE STEEL BEAMS. THE CONTRACT DRAWINGS SHALL INDICATE THE REQUIRED SPACING IN 4'-0" INCREMENTS.